

WORLD BEST FIRE FIGHTING SYSTEM & HEAT EXCHANGER

PNP GAS SYSTEM



Fire & Security

PNP INDUSTRIAL CO.



PNP OFFICE



FACTORY



PNP SEOUL

Specialized in manufacturing Fire Fighting Equipment and Protection System, Heat Exchanger, Gas Heater, Economizer, Recuperator, Industry Machinery, Environmental Equipment, Plant Construction & maintenance PNP Co. was established in Dec. 2000

We offer customized production with advanced world class technology and first-class quality standards for manufacturing processes.

As part of our effort to meet client's need and have our products to be the best quality in this field, we've been continuously developing technology, researching and investing the facility and equipment.

Through the co-operation with the world leading company in this industry by our well-experienced executives.

We have accumulated reputation on our items, it led us to show fully potentiality to prospective clients in the world market as promising manufacturer and exporter.

Our main strength lies in supplying the highest quality products and services at the most competitive price.

We will do our best everyday to be a step ahead and believe that it leads us more competitive ourselves as leading manufacturer and exporter.



MAJOR CUSTOMERS



<p>ASAHI</p>	<p>HITACHI Inspire the Next</p> <p>HITACHI LTD.</p>	<p>HITACHI Inspire the Next</p> <p>HITACHI SETSBU ENGINEERING CO., LTD.</p>	<p> 한화L&C</p> <p>HANWHA L&C</p>
<p>REACTOR</p>	<p>WATER COOLER , AIR TO AIR COOLER</p>	<p>WATER COOLER, AIR TO AIR COOLER</p>	<p>AIR COOLER, STEAM HEATER, OIL COOLER</p>
<p> 현대미포조선</p> <p>HYUNDAI MIPO DOCKYARD CO., LTD.</p>	<p>HYOSUNG</p> <p>HYOSUNG CO., LTD.</p>	<p> DOOSAN</p> <p>DOOSAN HEAVY</p>	<p> DOOSAN</p> <p>DOOSAN MECHATECH</p>
<p>GAS HEATER</p>	<p>WATER COOLER, COOLING UNIT, RADIATOR</p>	<p>HEAT EXCHANGER, GAS HEATER, ENVIRONMENTAL EQUIPMENT</p>	<p>HEAT EXCHANGER, GAS HEATER, ENVIRONMENTAL EQUIPMENT</p>
<p> 삼성테크윈</p> <p>SAMSUNG TECHWIN</p>	<p>posco</p> <p>POSCO (POHANG, KWANGYANG)</p>	<p>posco</p> <p>POSCO E&C</p>	<p>POONGSAN</p> <p>POONGSAN INDUSTRIAL CORP.</p>
<p>GAS HEATER, HEAT EXCHANGER</p>	<p>HEAT EXCHANGER, ECONOMIZER, RECUPERATOR, PLANT ...</p>	<p>HEAT EXCHANGER, ECONOMIZER, RECUPERATOR, PLANT ...</p>	<p>DRYER, HEAT EXCHANGER, OIL COOLER BUNDLE, UNIT HEATER...</p>
<p> SAMSUNG ELECTRO-MECHANICS</p> <p>SAMSUNG ELECTRO- MECHANICS</p>	<p> stx조선해양</p> <p>STX SHIPBUILDING CO., LTD.</p>	<p>TAIHEI Machinery Works Ltd.</p>	<p>ZPSS, QPSS (POSCO, CHINA)</p>
<p>AIR COOLER, HEAT EXCHANGER</p>	<p>GAS HEATER</p>	<p>L-TYPE HEATER, E- TYPE HEATER, FORMING FIN HEATER</p>	<p>OIL COOLANT SYSTEM</p>

Product List For...

FIRE EXTINGUISHING SYSTEM

○ **PNP N-100**
AGENT : NITROGEN

○ **PNP C-100**
AGENT : CO₂

○ **PNP FM-200**
AGENT : HFC-227EA

PNP FIRE EXTINGUISHING SYSTEM

PNP N-100
AGENT : NITROGEN

PNP N-100 System Configuration

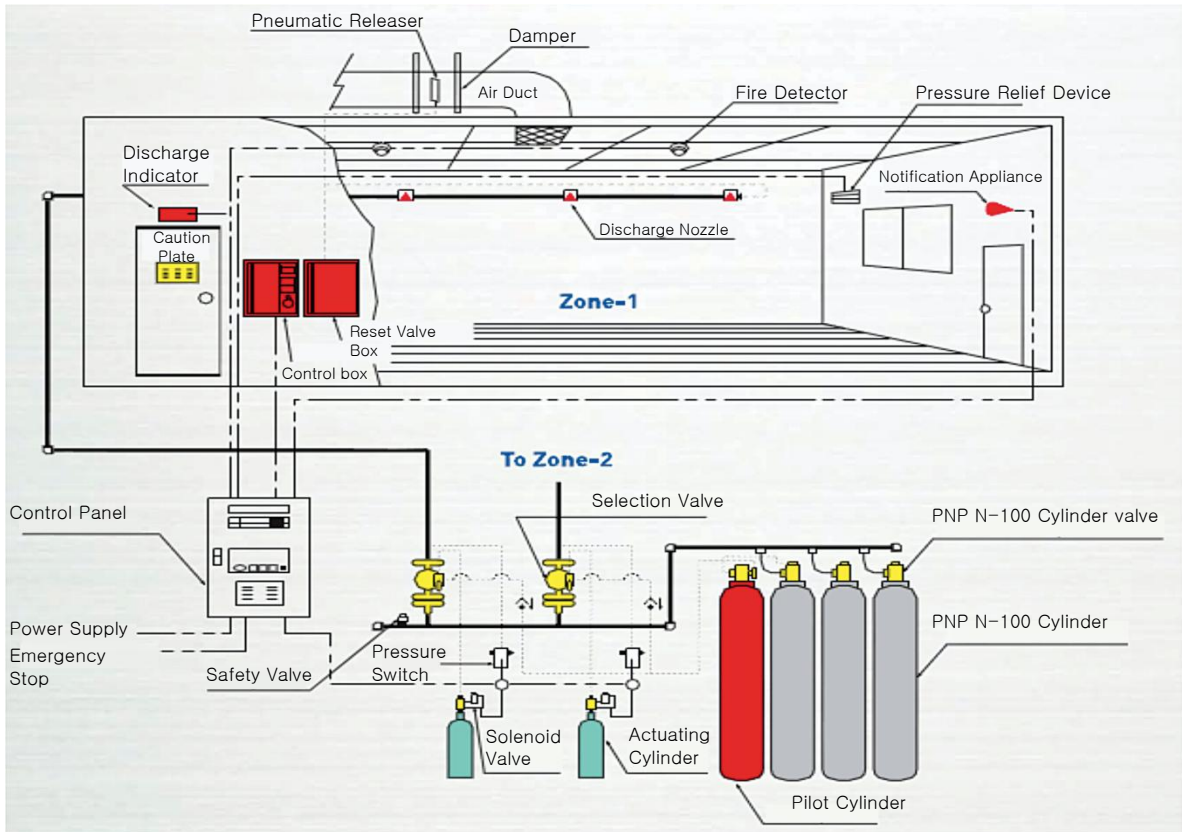

Operation Flow Chart

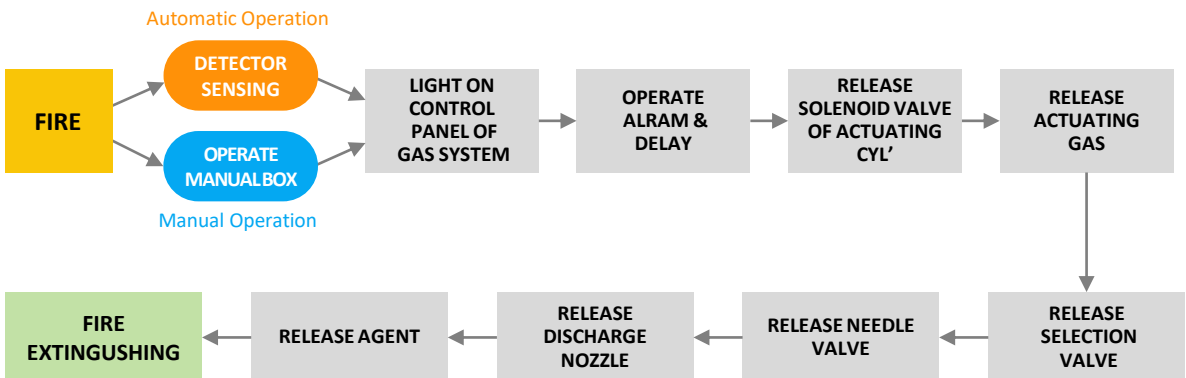

PNP FIRE EXTINGUISHING SYSTEM

PNP N-100
AGENT : NITROGEN

PNP N-100 Modular System



FIXED MODULAR SYSTEM(SEPERATE PIPE)

» FEATURE

- No need separated storage.
- Install muti-cylinder, 2 cyl' and more,
- Easy installation & maintenance.
- Any placed discharge nozzle installation with separated pipe.

» INSTALLAION PLACE

- ANY PLACE CAN BE INSTALLED CABINET TYPE AUTO-FIRE EXTINGUISHER.
- ANY PLACE REQUIRED MULTI- CYLINDERS W/O STORAGE.
- ANY PLACE REQUIRED SEPARATE PIPE W/O STORAGE.

» PRINCIAPL

- As total flooding system, it has same principal with common F/F system. It required small PILOT CYLINDER as actuator.

PNP N-100 MODULAR

SIZE	1B/T 590*450*2,200mm 2B/T 860*450*2,200mm 3B/T 1,190*450*2,200mm
MATERIAL	STEEL 1.6T
COLOR	Maker Standard
CYLINDER	84ℓ
CAPACITY	1B/T 17.4 m ³ 2B/T 34.8 m ³ 3B/T 52.2 m ³
PARTS	Gas cylinder, Solenoid v/v, Cylinder v/v, Tube, Discharge nozzle, Needle v/v, Copper tube 6A, Flexible hose, Pressure switch
PANEL	DC 24V IC AC 110V / 220V DC 24V Ni-Cd
OTHERS	Heat. Smoke detector, Release lamp, Manual control box, Siren, Pipe



PNP FIRE EXTINGUISHING SYSTEM

PNP N-100 AGENT : NITROGEN

Parts / KFI approved

>> Pilot Cylinder

Charged at 21°C, 100bar(10.0MPa) , actuated by CO₂ gas , used as actuator OF PNP N-100 Gas cylinder.
KS or KGSC APPROVED BOTTLE



Model No. ING087

SIZE	1,720mm(H)*279mm(O.D)*1,780mm(H) *273(O.D)		
CHARGING PRESSURE	10.0MPa at 21°C		
WORKING PRESSURE	15.0MPa	TEST PRESSURE	25.0MPa
MATERIAL	Mn Steel (KS B 6210)		
MAX. CYL' Q'TY	UNDER 150 BT		

>> PNP-100 Cylinder

Charged at 21°C, 223bar(22.3MPa) Cylinder's Charging capacity is 17.4m³.
KS or KGSC APPROVED BOTTLE



Model No. ING080

SIZE	1,715mm(H)*279mm(O.D)*1,765mm(H) *273(O.D)		
CHARGING PRESSURE	22.3MPa at 21°C		
WORKING PRESSURE	24.0 MPa	TEST PRESSURE	36.0MPa
CHARGING CAPACITY	17.4m ³	AGENT WEGHT	20.3Kg
MAX. CYL' Q'TY	UNDER 150 BT		

>> Pilot Cylinder Valve

Discharge N₂ from pilot cylinder.



Model No. SVP015

TYPE	F-Type
LEAK TEST	10.0MPa
MATERIAL	Brass (KS D 5101 C3771)

>> PNP N-100 Cylinder Valve

Reducing valve to make a gas stable discharging pressure from gas cylinder charged at 21°C, 223bar (22.3MPa).



Model No. SV010

LEA TEST	30.0MPa
WORKING PRESSURE	10.0MPa
DISCHARGING PRESSURE	9.0MPa
MATERIAL	Brass (KS D 5101 C3771)

PNP FIRE EXTINGUISHING SYSTEM

PNP N-100 AGENT : NITROGEN

Parts / KFI approved

>> Needle Valve

Burst copper plate of Pilot cylinder and Release Cylinder valve.



Model No. SVN006

SIZE	6mm
WORKING PRESSURE	1.8MPa
MATERIAL	Brass (KS D 5101 C3771)

>> 3way Control Valve

Install to release selector cylinder and control N2 discharge of Pilot cylinder.



Model No. SV017

SIZE	6A
LEAK TEST	10.0MPa
BURSTING TEST	15.0MPa
MATERIAL	Brass (KS D 5101 C3771)

>> Selection Valve

In case of single collecting tube consist of 2 more fire zone, release agent any fire zone required to.



Model No. SV015-25~150

W.P. 11.0MPa **PROOF TEST** 16.5MPa
LEAK TEST 13.2MPa

OPERATING TYPE Pneumatic Type
MANUAL OPERATING TYPE Lever Type

Stainless Steel Casting (KS D 4103 SSC13A)

DIA A	Model No.	FLANGE	LENGTH(±3)	HEIGHT(±3)
		D	L	
150A	SV015-150	305	415	550
125A	SV015-125	270	372	488
100A	SV015-100	225	330	434
80A	SV015-80	200	284	390
65A	SV015-65	175	257	347
50A	SV015-50	155	215	290
40A	SV015-40	140	200	270
32A	SV015-32	135	180	260
25A	SV015-25	125	170	244

PNP FIRE EXTINGUISHING SYSTEM

PNP N-100 AGENT : NITROGEN

Parts / KFI approved

Flexible Hose

Collected gas agent released from Cylinder valve to collecting tube, equipped in check valve.



Model No. SVF015

DIA	15A
LENGTH	450mm
LEAK TEST	10.0MPa
PROOF TEST	15.0MPa
MATERIAL	Stainless Steel (KS D 3706 STS 304)

Nozzle (360°)

To discharge gas agent into fire zone , equipped in orifice control agent volume & discharge time.



Model No. SP360-15~50

DIA 15A~50A
MIN. DISCHARGE PRESSURE. 29bar (2.9MPa)
MATERIAL Aluminum (KS D 6763 A6061) /
Brass (KS D 5101 C3604)

(Units: min)

Model No.	A	B	C	D	HOLE	ORIFICE(t)
SP360-50	82.6	78.1	56.9	10	24	3.2
SP360-40	61	65	45.1	8.1	18	2.0
SP360-32	69	57	39.3	8.0	18	1.5
SP360-25	55	44	30.2	6.5	18	1.8
SP360-20	50	39	24.3	7.3	8	1.5
SP360-15	37.2	30.6	18.8	5	8	1.5

Nozzle (180°)

To discharge gas agent into fire zone , equipped in orifice control agent volume & discharge time.



Model No. SP180-15~50

DIA 15A~50A
MIN. DISCHARGE PRESSURE. 29bar (2.9MPa)
MATERIAL Aluminum (KS D 6763 A6061) /
Brass (KS D 5101 C3604)

(Units: min)

Model No.	A	B	C	D	HOLE	ORIFICE(t)
SP180-50	80	78	56.8	19	7	23.4
SP180-40	75	65	44.6	15	7	20.4
SP180-32	68	58	39.0	12	7	18.0
SP180-25	56	44	30.3	9.5	7	13.0
SP180-20	49	37	24.2	7.5	7	11.5
SP180-15	42	30	18.7	6	7	9.0

PNP FIRE EXTINGUISHING SYSTEM

PNP N-100 AGENT : NITROGEN

Parts / KFI approved

>> Safety Valve

Protect collecting tube from the burst at over pressure.



Model No. SVS015/020

DIA	15A, 20A
WORKING PRESSURE	UNDER 9.0MPa
MATERIAL	Brass (KS D 5101 C3604)

>> Relief Valve

Prevent any incorrect-discharge at gas leakage of CO2 actuating cylinder.



Model No. SVR006

DIA	6A
CLOSING PRESSURE	0.1~0.3MPa
MATERIAL	Brass (KS D 5101 C3771)

>> Check Valve

Protect from the return of CO2 gas of actuating cylinder.



Model No. SVC006

DIA	6A
LEAK TEST	6.5MPa
PROOF TEST	9.8MPa
MATERIAL	Brass (KS D 5101 C3604)

>> Actuating Device

Release CO2 actuating gas from solenoid valve and selector valve & pilot cylinder valve.



Model No. SVA10

CAPACITY	0.64kg/ℓ
DIA	320mm(W)*125mm(D)*410mm(H)
MATERIAL	SSC 13A
PARTS	CYLINDER & VALVE, SOLENOID VAVLE, PRESSURE SWITCH

PNP FIRE EXTINGUISHING SYSTEM

PNP C-100
AGENT : CO₂

CO₂ SUPPRESSION SYSTEM



HIGH PRESSURE SYSTEM TYPE



AUTO-EXTINGUISHING TYPE



CABINET TYPE

DESCRIPTION	DESIGN BASE
MAINS	HIGH PRESSURE
INSTALLATION RANGE	ENGINE/PUMP/UPS ROOM, DANGEROUS CARGO HOLD, MANLESS OPERATED PLACE
HAZARD HEIGHT	MAX. 7.2M
HAZARD SPACE OF DISCHARGE NOZZLE	70.56m ²
DISCHARGEING TIME	SURFACE FIRE : 60 sec. INTENSE FIRE(50%) : 200sec.
ORIGIN	KOREA

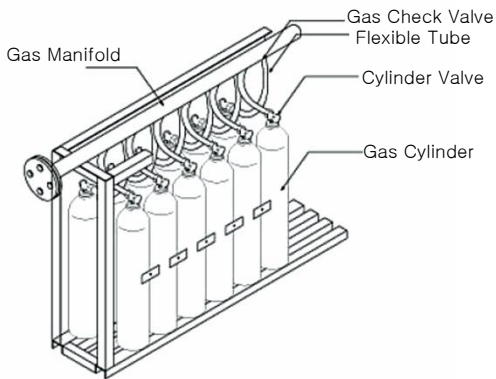

INSTALLATION FIGURE

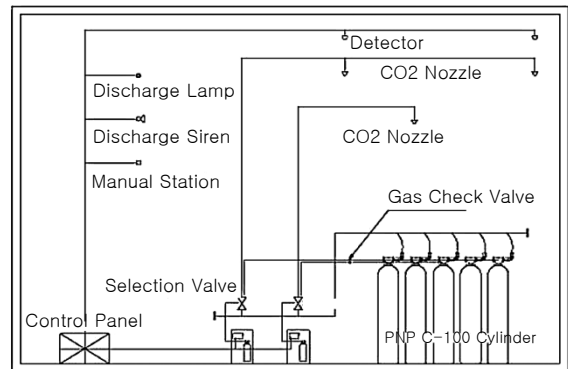

SYSTEM LAYOUT

PNP FIRE EXTINGUISHING SYSTEM

PNP FM-200
AGENT : HFC-227EA

HFC-227EA(FM200) SYSTEM



HFC-227EA SYSTEM TYPE



HFC-227EA MODULAR TYPE

DESCRIPTION	DESIGN BASE
MAINS	GASEOUS FIRE EXTINGUISHING SYSTEM
INSTALLATION RANGE	ALL PLACES FOR REPLACEMENT OF HALON 1301 SYSTEM
DISCHARGING TIME	10 sec.
HAZARD SPACE	20kg : 62m ² 30kg : 93m ² 50kg : 156m ² 100kg : 312m ²
ORIGIN	KOREA

ACCESSORIES & PARTS

CAPACITY	40L	68L	68L	87L
AGENT	HALON1301, HFC-125, HFC-227ea, HCFC-B/A, HFC-23		CO ₂	CO ₂
SIZE	232Ø 1.200mm(H)	267Ø 1.470mm(H)		280Ø 1.700mm(H)
CHARGED PRESSURE (20°C)	25kg/cm ² , 42kg/cm ²		59.6kg/cm ²	
Load Agent Max	97LBS	165LBS		

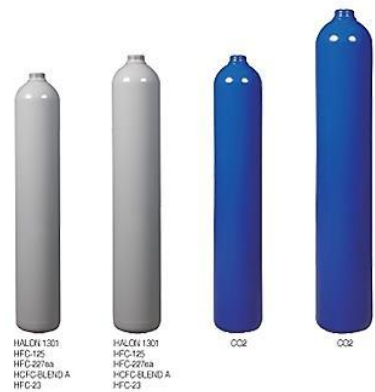

HALON 1301
HFC-125
HFC-227ea
HCFC-BLEND A
HFC-23

HALON 1301
HFC-125
HFC-227ea
HFC-BLEND A
HFC-23

CO₂

CO₂

CYLINDER

PNP FIRE EXTINGUISHING SYSTEM

FIRE EXTINGUISHING SYSTEM

ACCESSORIES & PARTS



CYLINDER VALVE



SELECTOR ION VALVE



ACTUATING DEVICE



NEEDLE VALVE



SOLENOID VALVE



FLEXIBLE HOSE



DAMPER RESET BOX



SAFETY VALVE



RELEIF VALVE



CEHCK VALVE



NOZZLE



MANUAL BOX



DISCHARGE LAMP

MEMO



PNP'S PROMISE

We will do our best everyday to be a step ahead and believe that it leads us more competitive ourselves as leading manufacturer and exporter.

We will give you the better one than what you need.

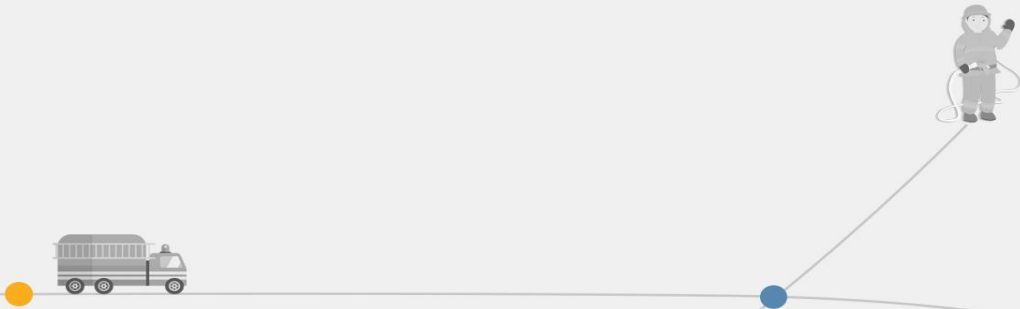

PEOPLE & PEOPLE

PHUONG NAM TEC., JSC OFFICIAL DISTRIBUTOR IN VIETNAM

PNTEC - Office

No.9, Vong Ha street, Hoan Kiem District
Hanoi, Vietnam.

PNTEC – Sales Office

10 Floor, Hoang Ngoc Building, Lance 94, Tran Thai Tong Street.,
Cau Giay District., Hanoi, Vietnam

PNTEC – HCM Office

No. 130/14, Tran Thai Tong Street, Ward 15, Tan Binh District.,
Ho Chi Minh City, Vietnam

Tel +84-4-3 556 1436 Fax +84-4-3 556 1435
SALES DEPT. E-mail pccphuongnam@gmail.com



Fire & Security